

VHM mechanical vacuum lifters



REMA VHM mechanical vacuum lifters are ideal for use in places where there is no energy source.

Properties

- No energy source required.
- Easy and quick installation.
- Ergonomic control by one operator.
- Low maintenance.
- TÜV certified.

Norm:

- EN12100-1/2, EN13155

Safety

- Vacuum protection against release.
- Acoustic signal in case of pressure loss with 2 x 9 V batteries (not rechargeable).
- Pressure gauge and vacuum control.
- Green and red LED for "safe operation".
- Minimum load 3 kg.

IMPORTANT:

Always check on the material specifications and dimensions (L x W x D) of the sheet or workpiece to be lifted.

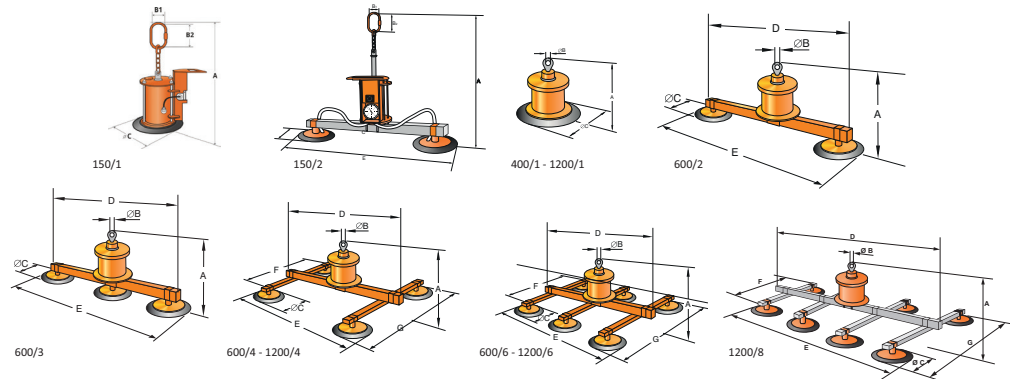

Option

Safety bar to ensure there is always enough distance between man and machine.

Type	WLL (kg)	Number of pistons	Thickness (mm) plate 1000 x 2000 mm	Thickness (mm) plate 1250 x 2500 mm	Thickness (mm) plate 1500 x 3000 mm	Weight (kg)	ProductId
VHM-100/1	100	1	>5	-	-	17	3665000
VHM-150/2	150	2	>3	>5	-	26	3665002
VHM-400/1	400	1	>5	-	-	46	3665001
VHM-600/2	600	2	>1	>1.5	>4	83	3665003
VHM-600/3	600	3	>1	>1	>3	96	3665005
VHM-600/4	600	4	>1	>1	>2	110	3665007
VHM-600/6	600	6	>1	>1	>1	136	3665008
VHM-1200/1	1200	1	>5	-	-	130	3665010
VHM-1200/4	1200	4	>1	>1	>2	188	3665009
VHM-1200/6	1200	6	>1	>1	>2	228	3665011
VHM-1200/8	1200	8	>1	>1	>2	266	3665013

Type	A min (mm)	A max (mm)	B (mm)	C (mm)	D (mm)	E min (mm)	E max (mm)	F (mm)	G min (mm)	G max (mm)
VHM-100/1	495	580	60x110	230	-	-	-	-	-	-
VHM-150/2	610	750	50	230	1910	470	1160	-	-	-
VHM-400/1	440	580	50	400	-	-	-	-	-	-
VHM-600/2	610	750	50	400	1910	860	2210	-	-	-
VHM-600/3	620	810	50	400	1910	1250	2210	-	-	-
VHM-600/4	690	880	50	340	1910	740	2140	1480	630	1740
VHM-600/6	690	880	50	280	1910	900	2080	1480	570	1680
VHM-1200/1	544	754	60	770	-	-	-	-	-	-
VHM-1200/4	800	1010	60	410	1910	950	2210	1200	850	1500
VHM-1200/6	800	1010	60	410	1910	1250	2210	1200	850	1500
VHM-1200/8	800	1010	60	410	1910	1250	2210	1200	850	1500